



© 2007 The German Marshall Fund of the United States. All rights reserved.

No part of this publication may be reproduced or transmitted in any form or by any means without permission in writing from the German Marshall Fund of the United States (GMF). Please direct inquiries to:

The German Marshall Fund of the United States  
1744 R Street, NW  
Washington, DC 20009  
T 1 202 745 3950  
F 1 202 265 1662  
E [info@gmfus.org](mailto:info@gmfus.org)

This publication can be downloaded for free at <http://www.gmfus.org/publications/index.cfm>. Limited print copies are also available. To request a copy, send an e-mail to [info@gmfus.org](mailto:info@gmfus.org).

#### **GMF Paper Series**

The GMF Paper Series presents research on a variety of transatlantic topics by staff, fellows, and partners of the German Marshall Fund of the United States. The views expressed here are those of the author and do not necessarily represent the view of GMF. Comments from readers are welcome; reply to the mailing address above or by e-mail to [info@gmfus.org](mailto:info@gmfus.org).

#### **About GMF**

The German Marshall Fund of the United States (GMF) is a non-partisan American public policy and grant-making institution dedicated to promoting greater cooperation and understanding between the United States and Europe.

GMF does this by supporting individuals and institutions working on transatlantic issues, by convening leaders to discuss the most pressing transatlantic themes, and by examining ways in which transatlantic cooperation can address a variety of global policy challenges. In addition, GMF supports a number of initiatives to strengthen democracies.

Founded in 1972 through a gift from Germany as a permanent memorial to Marshall Plan assistance, GMF maintains a strong presence on both sides of the Atlantic. In addition to its headquarters in Washington, DC, GMF has six offices in Europe: Berlin, Bratislava, Paris, Brussels, Belgrade, and Ankara.





# 1 THE PROBLEM

Agriculture in many industrialized countries is heavily subsidized.<sup>1</sup> The Common Agricultural Policy (CAP) of the European Union provides subsidies in a variety of ways. They include agricultural producer price support (by means of import restrictions, export subsidies, domestic production quotas, minimum producer prices, and the like) and direct payments, which are to a large degree decoupled from production. Likewise, U.S. farmers receive subsidies through Loan Deficiency Payments as well as other support mechanisms. Economic theory stipulates that agricultural subsidies are capitalized to a large extent into the purchase and the rental price of agricultural land. This is so because the supply elasticity of land is lower than the demand elasticity. Thus, it is the landowners rather than the farm operators who are often the main beneficiaries of EU and U.S. farm policies.

To the extent that farmers own the land they farm, they do benefit from current policies. However, when operations are expanded, be it through land rental or through the purchase of land, the rents end up not in the pockets of operators but instead go to the owners or sellers of the land. Therefore, it can be anticipated that the larger part of the benefits from agricultural subsidies on both sides of the Atlantic ends up not with farm operators, but with landowners.

The central research objective of this paper is to analyze the market for agricultural land in Germany and the United States and to determine how agricultural subsidies affect the price of land. The results of the analysis provide an answer to the question as to what portion of farm subsidies leaks out to the landowners and how much stays with the operator.

---

<sup>1</sup> is is not the case, however, in *all* industrialized countries. Both New Zealand and Australia have undergone ambitious programs of agricultural policy reform, including significant reductions and phase-outs of farm subsidies.

## 2 CHARACTERISTICS OF THE AGRICULTURAL LAND MARKETS IN GERMANY AND THE U.S.

### 2.1 Germany

German agriculture is undergoing rapid structural change. During the past 10 years, the number of farms has declined by 25 percent (BMELV, var. vols.). At present, there are approximately 350,000 agricultural operations in Germany, farming an area of about 17 million hectares (ha). Around 60 percent of total agricultural land is rented, while 70 percent of operations farm at least some rented land (DESTATIS, 2006). The share of rented land in total farm land has increased since the early 1990s. (Figure 1)

The larger a farm, the higher is the proportion of rented land. This is due to the fact that in Germany, unlike in the United States, individual growth of farms is predominantly realized through land rental rather than land purchases. Typically, land rental contracts are signed for a period of six to 12 years.

Due to historical reasons there is significant difference in the prevalence of land rentals between the former West and East Germany. In West Germany, the proportion of rented land has increased steadily from around 30 percent in the

early 1980s to over 50 percent currently, while in the East this number has been at about 80 percent since the unification of Germany in 1990.

It is worth noting that the price of rental land is significantly different between East and West (Figure 2; Tables 1 and 2). In 2005, the average rental price in the East was only about 55 percent of the price in the West. It is evident also that the rental price in the West has been roughly constant since German unification, while in the East it has gone up by about 40 percent.

The reasons for the differences in land rental prices and their change over time between Western and Eastern Germany are manifold (e.g. Doll, 2002; Neue Landwirtschaft, 2007):

- In the first few years after unification, farms in the East were short of capital and capital markets were not yet fully functioning as banks were not yet used to dealing with agricultural loans to farms with little collateral in the form of owned land.
- The German agricultural land privatization agency, which dominated the land rental

Figure 1: The Growing Importance of Agricultural Land Rental in Germany, 1991–2005

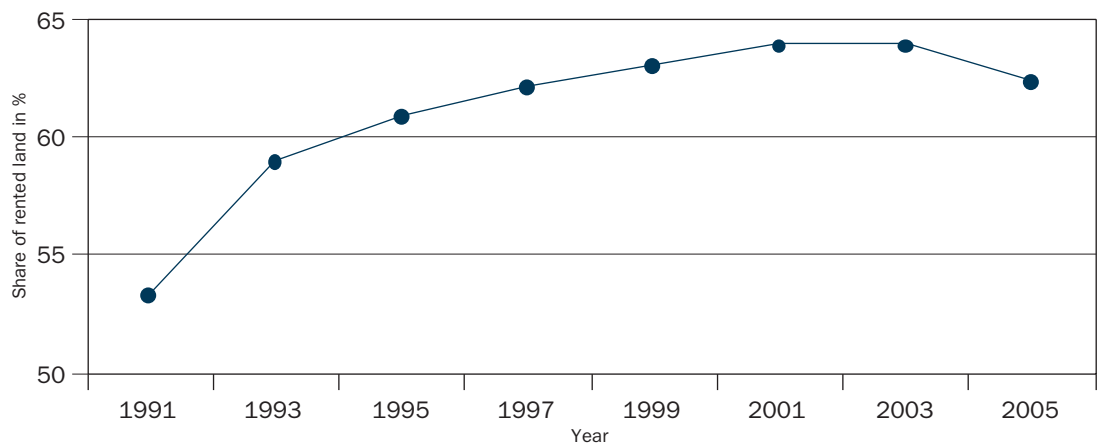

Source: Adopted from Doll (2002) and DESTATIS (var. vols.)

Figure 2: The Rental Price of Agricultural Land in Germany, 1991–2005

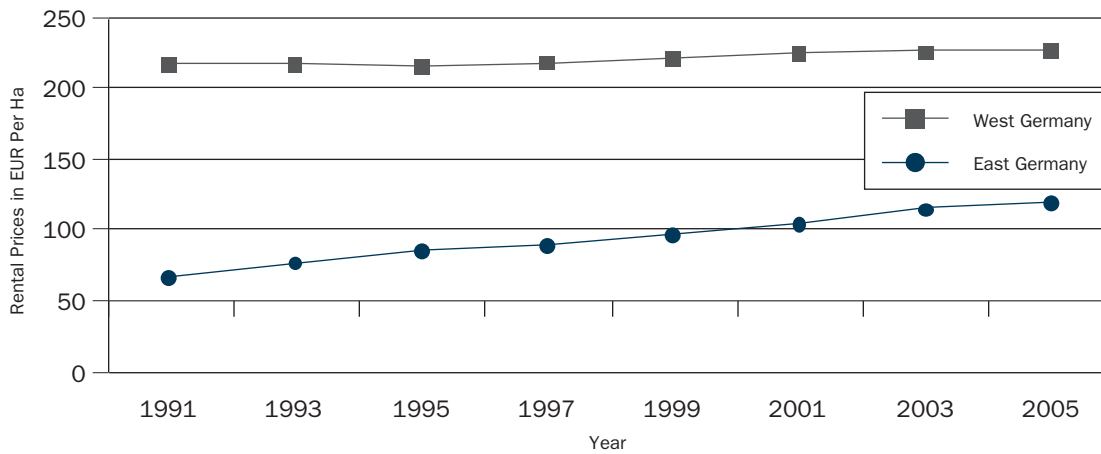

Source: Adopted from Doll (2002) and DESTATIS (var. vols.)

market in the East in the early years of German unification, rented out land to farmers at below market prices.

- In the West there continues to be a more intense competition for land, while large farms in the East often have monopsony market power in the local land markets.
- Eastern Germany is less densely populated than the West; therefore, the average distance to the market is longer, and agricultural commodity prices tend to be lower.
- Average land quality is lower in Eastern than in Western Germany, and the climatic conditions are somewhat less favorable (colder winters and less precipitation).

As will be discussed in greater detail later, the CAP has been in a process of reform since the early 1990s. In the course of this reform process, traditional farm subsidies have been reduced significantly. They have been replaced by direct payments, which are to a large extent decoupled from actual production, and by subsidies for

the production of bioenergy, such as biogas and biofuels. Notice that the bioenergy subsidies are not considered agricultural subsidies. Hence, they are often neglected in analyses of agricultural subsidies.

As Figure 3 suggests, the net effect of CAP reforms on total agricultural support has been marginal and, hence, the effect on land rental prices has been insignificant. In this figure, agricultural policy is characterized by the index of agricultural producer prices and the producer subsidy equivalent (PSE), which is an aggregate measure of agricultural policy support initially put forward by the Organisation for Economic Co-operation and Development (OECD) and now widely used in economic analyses and international trade negotiations. As is evident, the process of CAP reform has only slightly reduced the political support of EU agriculture, as both the agricultural producer price index and the PSE have declined by less than 20 percent since 1991. Land rental prices have increased by more than 20 percent during the same time period. This merely reflects the catching up process of land rental prices in Eastern Germany.

**Table 1: The Price of Crop Land in New (Multiyear) Rental Agreements, 1999 and 2005<sup>1</sup>**

Region	Rental land price (EUR per ha)		Change in price of rental land (percent)
	1999	2005	
West German Länder	285	295	3
Baden-Württemberg	206	256	24
Bayern	292	269	-8
Hessen	177	211	19
Niedersachsen	326	337	3
Nordrhein-Westfalen	372	394	6
Rheinland-Pfalz	190	201	6
Schleswig-Holstein	314	296	-6
East German Länder	119	140	18
Brandenburg	81	86	6
Mecklenburg-Vorpommern	105	147	40
Sachsen	106	135	27
Sachsen-Anhalt	167	186	11
Thüringen	120	165	37

Source: Adopted from DESTATIS (var. vols.).

**Table 2: The Price of Pasture and Grazing Land in New (Multiyear) Rental Agreements, 1999 and 2005<sup>1</sup>**

Region	Rental land price (EUR per ha)		Change in price of rental land (percent)
	1999	2005	
West German Länder	163	146	-10
Baden-Württemberg	128	113	-12
Bayern	176	162	-8
Hessen	84	89	6
Niedersachsen	173	148	-14
Nordrhein-Westfalen	195	182	-7
Rheinland-Pfalz	98	85	-13
Schleswig-Holstein	198	174	-12
East German Länder	61	69	13
Brandenburg	54	64	18
Mecklenburg-Vorpommern	61	70	15
Sachsen	61	75	23
Sachsen-Anhalt	67	71	6
Thüringen	68	65	-4

Source: Adopted from DESTATIS (var. vols.).

<sup>1</sup> Not included are Berlin, Bremen, Hamburg, and Saarland.



**Figure 3: Land Rental Prices and Agricultural Subsidies, 1991-2005 (1991 = 100 per cent)**

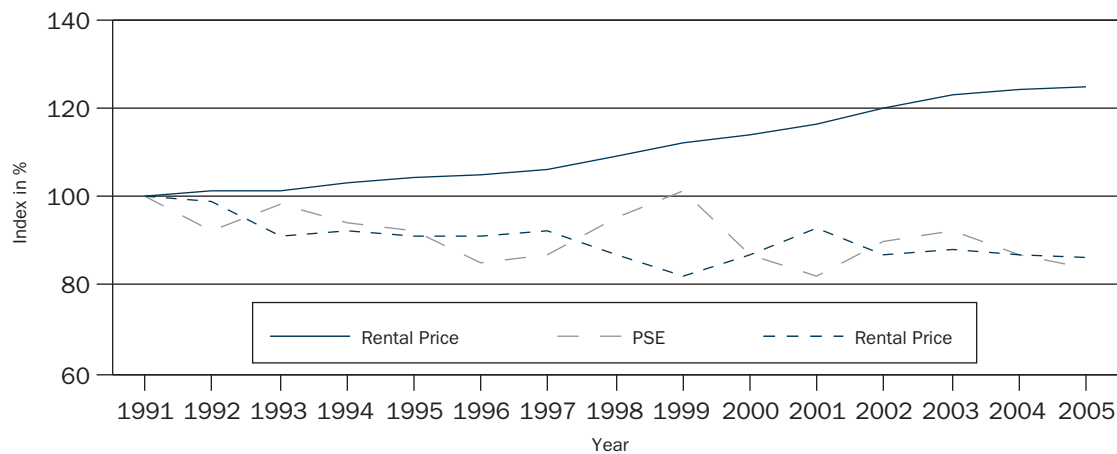

Source: Adopted from BMELV (2007), DESTATIS (var. vols.), OECD (2007)

## 2.2 United States

Similar to the situation in Germany, the United States is undergoing significant changes with respect to its farm structure. Based on the 2002 Census of Agriculture (NASS, 2002), there were approximately 2.13 million farm operations in the United States farming just over 938 million acres of land. This represents a decrease in farm numbers of 3.92 percent from 1997 and a decrease in farmland of 1.76 percent during the same period. Although the number of small, part-time farmers is increasing in the United States, especially in areas on the fringe between urban and rural areas, these numbers signify a national trend toward larger farms. (Tables 3, 4, and 5)

Structural adjustment in agriculture can also be examined at the state level, given the vast differences in land and farming within a country as large and diverse as the United States. This has been done for Minnesota and Virginia. Percentage changes in number of farms in Virginia were quite similar to those exhibited for the United States as a

whole, indicating an increase in average farm size. However, the changes for the Midwestern State of Minnesota reveal a 2.65 percent increase in the number of farms, accompanied by only a slight, 0.17 percent, decrease in overall farm acreage.

These differences between states are indicative of their unique agricultural systems and demographic trends. In particular, these changes in farm numbers and land in agriculture are influenced by two of the main factors that affect the price of agricultural land. These are alternative uses for agricultural land, and the ability of agricultural land to generate revenue. Agricultural land values are exhibited in Table 6.

In the case of Virginia, agricultural land has felt the pressures of urban infringement for many years. The existence of dense population centers both within Virginia and in surrounding states has exerted pressure on agricultural land from alternative uses, thus putting upward pressure on the price of agricultural land and pulling land out of agriculture. At the same time, government

Table 3: Farms Numbers, 1997 and 2002				
Land in Farms	Number of Farms		Change	
	1997	2002	Numbers	Percent
Minnesota	78,755	80,839	2,084	2.65
Virginia	49,366	47,606	-1,760	-3.57
United States	2,215,876	2,128,982	-86,894	-3.92

Source: USDA/NASS (var. vols.).

Table 4: Land in Farms and Harvested Cropland, 1997 and 2002			
Land in Farms	Farmland area (Acres)		Change in farmland
	1997	2002	Percent
Minnesota	27,560,621	27,512,270	-0.17
Virginia	8,753,625	8,624,829	-1.49
United States	954,752,502	938,279,056	-1.76
Harvested Cropland			
Minnesota	19,794,078	19,398,309	-2.04
Virginia	2,600,860	2,623,776	0.88
United States	318,937,401	302,697,252	-5.37

Source: USDA/NASS (var. vols.).

Table 5: Total Cropland, 1982-2002					
Region	1982 1,000 Acres	1987 1,000 Acres	1992 1,000 Acres	1997 1,000 Acres	2002 1,000 Acres
Minnesota	24,183	23,422	23,511	22,839	23,264
Virginia	4,753	4,613	4,436	4,340	4,168
48 States <sup>1</sup>	468,888	463,580	459,654	454,691	441,273

Source: USDA/ERS (2007).

<sup>1</sup> Excludes Alaska and Hawaii.

programs that provide direct subsidies to agriculture are capitalized into the value of agricultural land, especially when these payments are directly linked to the productivity of the land. Government support to Tobacco producers, in particular, is one program that has influenced the revenue stream of Virginia's agricultural land.

On the other hand, Minnesota is much more rural than Virginia. Although agricultural land in Minnesota has begun to experience pressure from

alternative uses, some of the recent transition of land out of large-farm agriculture has involved an increase in the number of small, part-time farming operations on the urban-rural fringe. This may explain the increased number of farms in Minnesota between 1997 and 2002. In addition, the composition of agriculture in Minnesota is dominated by large grain and livestock producing operations. Government payments play an important role in Minnesota agriculture.

**Table 6: Average Dollar Value of Cropland per Acre, 2002-2006**

Region	2002 USD	2003 USD	2004 USD	2005 USD	2006 USD	Change 2005-2006 Percent
Northeast	3,210	3,400	3,800	4,390	5,040	14.8
Lake States	1,720	1,860	2,030	2,270	2,550	12.3
Corn Belt	2,180	2,270	2,450	2,880	3,230	12.2
Northern Plains	720	737	783	916	1,040	13.5
Appalachian	2,340	2,490	2,670	3,040	3,450	13.5
Southeast	2,240	2,350	2,460	3,660	4,550	24.3
Delta States	1,160	1,210	1,270	1,460	1,600	9.6
Southern Plains	808	863	902	1,010	1,180	16.8
Mountain	1,120	1,170	1,200	1,420	1,750	23.2
Pacific	3,410	3,500	3,570	4,620	4,850	5.0
Minnesota	1,430	1,520	1,690	1,950	2,180	11.8
Virginia	2,550	2,800	3,300	4,100	5,300	29.3
48 States <sup>1</sup>	1,590	1,660	1,770	2,110	2,390	13.3

Source: USDA/NASS (var. vols.).

<sup>1</sup> Excludes Alaska and Hawaii.

# 3 THEORETICAL FRAMEWORK

In principle, the market for agricultural land is like any market in that the price of land is determined by supply and demand. Economic theory stipulates that the demand function for land is equivalent to the value marginal product. For the market of rented land the value marginal product is the present value of the expected value marginal product for each year of the rental contract. For the purchase market of land, it is the present value of the expected value marginal product for an infinite number of periods. In the following, we will consider the rental market of agricultural land and assume that the length of a rental contract is one year. Then the value marginal product is:

$$(1) \text{VMP}_1 = (Q/L) \cdot P = D_1$$

$\text{VMP}_1 =$  Value marginal product.

$Q/L =$  Physical marginal product of agricultural land; the physical marginal product represents the change in quantity produced that results from one additional unit of land, all other things being equal.

$P =$  Price of the good produced on the land.

$D_1 =$  Demand for agricultural land.

There are two determinants of the demand for land. One is the marginal land productivity and the other is the price of the good being produced on the land. The price, in turn, may be determined by agricultural policy. In fact, the PSE measure discussed above converts all types of agricultural support into the equivalent subsidy and thus the price effect of government support. Therefore, the PSE is often used to determine the effect of agricultural policy on the price of land.

The supply of agricultural land is determined by a number of variables (e.g. Trivelli, 2007); one of which is the price. However, evidence

suggests that the supply of agricultural land is rather inelastic with regard to its price. That is, the quantity of land supplied on the market does not react much to a change in price. This is important because it is the magnitude of the price elasticity of supply relative to that of the demand which determines the distribution of policy benefits between market participants.

Generally, the market side which is less responsive to price changes, and thus to subsidies, reaps the larger part of a subsidy regardless of who has actually paid the subsidy. Hence, one may indeed expect that most of the benefits of agricultural subsidies do not stay with the operator. Rather, they leak out to the land owner. The portions of a subsidy going to landowners and tenants respectively can be calculated as follows:

$$(2) \frac{\text{Portion of subsidy going to landowners}}{\text{Portion of subsidy going to tenants}} = \frac{d}{s}$$

$d =$  Price elasticity of the demand for rental land; i.e.

(percent change in demand for rental land) / (percent change in price of rental land)

$s =$  Price elasticity of the supply of rental land; i.e.

(percent change in supply of rental land) / (percent change in price of rental land)

Figure 4 depicts the land market with a subsidy paid to farmers for what they produce. The horizontal axis denotes the amount of land (L), while the vertical axis denotes the price of land (r) and the value marginal product of the land ( $\text{VMP}_1$ ). Notice that the supply function (S) is less elastic (steeper) than the demand functions ( $\text{VMP}_1^0$  and  $\text{VMP}_1^1$ ). Figure 4 depicts a typical agricultural land market.  $\text{VMP}_1^0$  represents the value marginal product and thus the demand for land in the absence of the subsidy. The producer price effect

Figure 4: The Land Rental Price Effect of Agricultural Producer Price Support

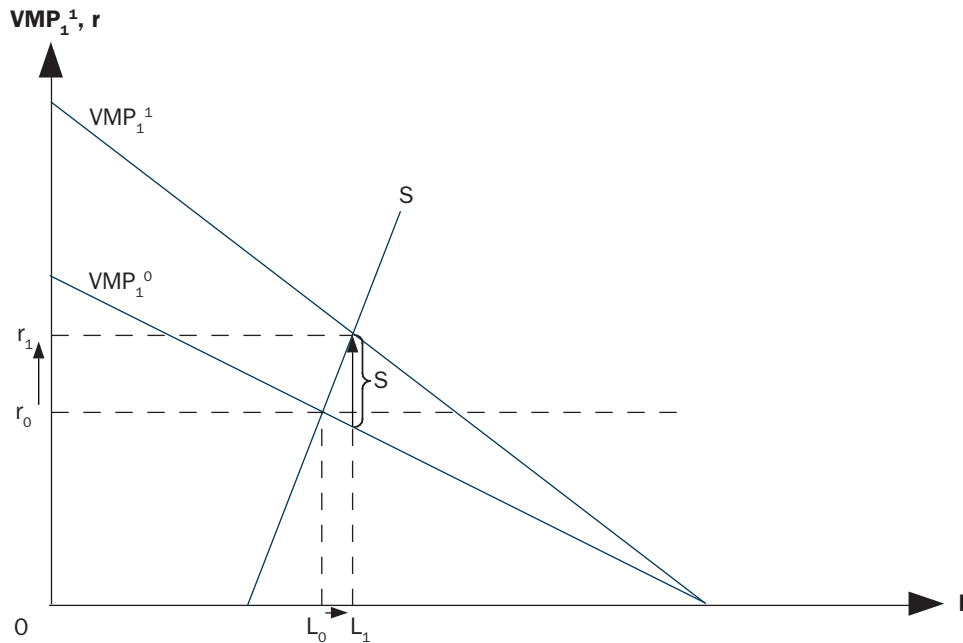

of the subsidy moves  $VMP_1^0$  proportionally upward to  $VMP_1^1$ . As becomes obvious, most of the price effect of the subsidy ( $S$ ) is translated into an increase of the price of land from  $r_0$  to  $r_1$ . The remainder of the subsidy remains with the tenant.

### 3.1 Specification for Germany

The situation on the land market in the European Union and in Germany is somewhat more complicated, as there are not only traditional agricultural price supports but also direct payments to farmers which to a large extent are decoupled from actual production and, therefore, are not directly linked to production. The payments are made as a constant amount of EUR per hectare. The proponents of this policy claim that the decoupled payments have no major impact on production.

As mentioned above, in the process of CAP reform agricultural support prices have been reduced significantly. All other things being equal, this has acted to reduce the value marginal product of agricultural land and, thus, the price of farm land. The reduction of agricultural producer price support, however, has been paralleled by the introduction of direct payments and of subsidies for bioenergy production. In essence, one type of subsidy has been replaced by others. Hence, it is not surprising that there has been no major impact on the price of rental land as a consequence of farm policy reform in the European Union (Bahrs and Held, 2007).

The portion of direct payments which are decoupled from actual production decisions are sometimes thought of as having no incentive effect

and, thus, no significant effect on agricultural rental land prices. However, this consideration is based on an overly simplistic model of neoclassical economics that leaves out much of what matters in this regard, as it implies that the liquidity effect of subsidies does not matter, that farmers hold no expectation about future changes in agricultural policies, and that the assurance of a steady stream of cash from the government does not affect production and investment decisions. The experience with decoupled payments in the United States under the 1996 Freedom to Farm Act and in the EU supports the view that this type of subsidy has significant incentive effects in the real world (Ahearn et al., 2007; Hennessy and Thorne, 2005) and, subsequently, on farm land prices. In fact, casual observation of recent developments on German agricultural land markets which do not yet show up in the published land market data suggest that the direct

payments together with the subsidies for the production of bioenergy have acted to significantly increase the rental price of agricultural land.

The effect of the direct payments on land rental prices can be accounted for by a parallel shift of the demand function (Lippert, 2001). This is depicted in Figure 5.

The market situation is identical to Figure 4 except that there is an additional parallel shift of the value marginal product curve to  $VMP_1^2$ . Again at the new price ( $r_2$ ) most of the policy benefits ( $S$ ) go to the suppliers, i.e. the landowners in the form of an increased rent.

As we shall see later, on average, the rental price of agricultural land in Germany would be negative in the absence of agricultural subsidies, all other things being equal. This is depicted in Figure 6, where the rental price of land without subsidies ( $r_1$ )

**Figure 5: The Land Rental Price Effect of Agricultural Producer Price Support Plus Direct Payments**

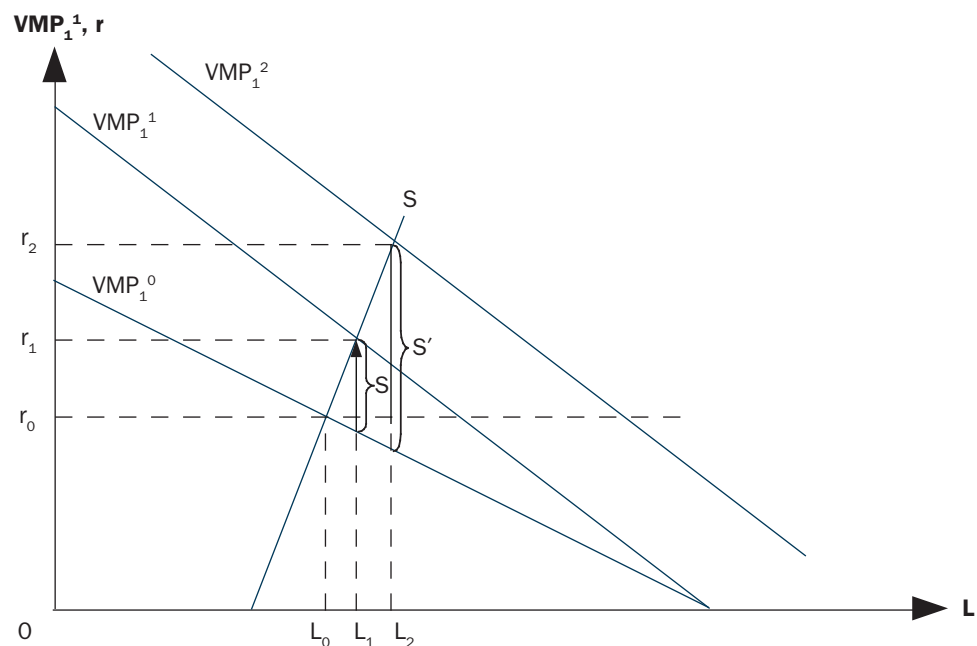

Source: Adopted from Lippert (2001).

**Figure 6: The Land Rental Price of Agricultural Land Would be Negative in the Absence of Subsidies in Certain Regions of Germany (Eastern Germany, Poor Soils)**

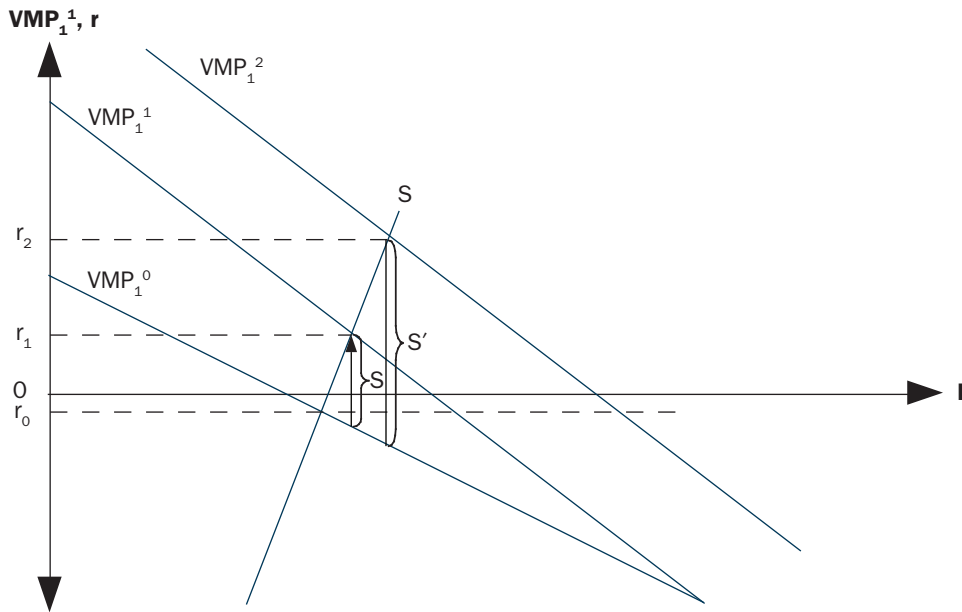

is negative; i.e., the subsidy exceeds the land rent.

### 3.2 Specification for the United States

As indicated in the previous section, the value of agricultural production and government payments, both coupled and decoupled, serve to impact the value of agricultural land. Economic theory suggests that land prices are positively related to the revenues generated from production, and government payments that affect production (coupled payments). Notice that revenues (without government payments) still contain subsidies to agriculture in the form of minimum producer prices. Therefore, revenues change as much as

prices change when there is a change in government regulated prices. This can easily be seen as follows:

$$(3) R = P \cdot Q$$

R = Revenue.

Q = Quantity of the good produced on the land.

$$(4) dR/R = dP/P + dQ/Q$$

However, the impact of decoupled payments on land values is not as clear. Decoupled payments could increase the willingness of individuals to hold land, in which case the relationship would be positive. On the other hand, decoupled

payments linked to environmental or conservation practices that increase costs to the farmer or the land-owner could exert downward pressure on cash rents and land values. As a result, the impact of decoupled payments is ambiguous.

In order to examine the determinants of land values, the following basic economic model is proposed:

- (5) Land Value = f (Cash Receipts (incl. subsidies in the form of minimum prices), Coupled Government Payments, Decoupled Government Payments).

In addition to these three primary independent variables, the value of agricultural land may be influenced by other factors. For example, the existence of other alternative uses, such as residential use, may cause the value of land to increase over time. To account for this, time trend variables will be incorporated into the empirical model. Also, differences between states or counties may exist due to the type of crop being produced or the way in which the government chooses to support production of a specific crop or region. To account for differences of this type, this analysis will use a dummy variable to ascertain the differences in land values due to tobacco production.



# 4 THE DISTRIBUTION OF POLICY BENEFITS BETWEEN LANDOWNERS AND OPERATORS

## 4.1 Evidence for Germany

In the literature there is no complete agreement on the leakage of agricultural subsidies to landowners. Most authors suggest that the supply elasticity of agricultural land is zero (e.g. Chambers, 1995; Höper, 1985). This would imply complete capitalization of subsidies into land rental prices and land values. Other authors find a less than complete incidence of capitalization of agricultural subsidies into land values (e.g. Isermeyer, 2003; Fuchs, 2002; Gömann, 2002). In our analysis, we have used a conservative approach and have based our calculations on a supply elasticity which is positive but fairly small (0.1). The demand elasticity used here is 0.2. These numbers are in line with recent estimates by Zeddies (2003).

The elasticities used in the calculations imply (equation 2) that of each EUR in farm subsidies the land owner receives EUR 0.67 while the tenant gets EUR 0.33. Table 7 exhibits the distribution of farm policy benefits between landowners and

operators. Subsidies included in the calculations are all direct payments and price supports. Remember that the reform of the CAP has resulted in a significant reduction of support prices, except for dairy and sugar. Therefore, a large proportion of support is now provided through direct payments.

The typical land rental agreement is such that the tenant pays the cash rent and covers the cost of landownership such as property taxes, maintenance of farm roads, water use fees, and the like. Data available for this analysis contains information about cash rents only. The non-cash rent is typically in the range of EUR 40 to EUR 60 per hectare. In the calculations for Table 7 it has been assumed that the non-cash rent is EUR 50 per hectare and included in the price of rental land.

Table 7 indicates that total subsidies are substantial at about EUR 550 per hectare. Of those, operators obtain less than EUR 200, while more than EUR 350 are passed on to landowners.

**Table 7: The Distribution of Farm Policy Benefits Between Landowners and Operators in Germany, 2005/06**

Region	Western Germany	Eastern Germany
Total subsidies (EUR per ha) <sup>1</sup>	568	533
Price of rental land with subsidies (EUR per ha) <sup>2</sup>	375	240
Subsidies leaking out to land owners (EUR per ha)	379	355
Subsidies staying with operators (EUR per ha)	189	178
Price of rental land without Subsidy (EUR per ha)	-4	-115

Source: Own calculations based on BMELV (2007).

<sup>1</sup> The total subsidy is market price support plus all direct payments. It is equivalent to  $s'$  in Figure 6.

<sup>2</sup> Cash rent plus owners' land cost paid by the operators.

The numbers in the bottom line of Table 7 are quite shocking at first glance, as in a typical German farm the return to agricultural land, i.e. the price of rental land, would be negative in the absence of farm subsidies. However, on second look these numbers should not be surprising at all. They reflect four well documented phenomena, some of which are related.

- (i) Neither U.S. nor European farmers would be able to cover the cost of production on many markets at the low world market prices that prevailed in the vast majority of the past 30 years. For instance, the United States is a major wheat exporter, but the typical farmer cannot cover the cost of production (e.g. USDA/ERS, 2007). Likewise many German farms would experience an economic loss even with existing price support if they did not receive direct payments (von Witzke and Noleppa, 2006).
- (ii) The depressed agricultural world market prices are, to a large degree, the result of farm subsidies paid out by the United States and European Union. (e.g. Tyers and Anderson, 1992). Both are large players in agricultural trade—in fact, they are the world’s two most important agricultural exporters. In both, farmers are the recipients of subsidies on a significant scale. U.S. and EU farm subsidies stimulate production and exports which,

in turn, act to depress world market prices (von Witzke and Hausner, 1997). In other words, agricultural subsidies have created the paradoxical situation in that they have depressed agricultural world prices on many markets to levels at which neither the typical U.S. nor EU farmer can compete. For instance, the U.S. Department of Agriculture (2007) lists the cost of wheat production as exceeding the value of wheat production in all regions of the United States in 2004 and 2005. The depressed world market prices, in turn, are used by proponents of current policies as an argument to defend agricultural subsidies.

- (iii) Subsidies tend to reduce efficiency and international competitiveness (EU, 2003). In the absence of subsidies, farmers would be forced to realize efficiency gains (e.g. von Witzke and Noleppa, 2006).
- (iv) Farm subsidies have also led to the fact that today some land is used for farming which in the absence of subsidies would not be farmed, and would probably be covered by forests.

The effect of subsidies on the price of rental land is illustrated further in Table 8. It exhibits the share of agricultural land used for sugar beet production and the price of rental land in six selected Landkreise (administrative districts) of Germany.

Table 8: The Effect of Sugar Beet Price Support on Farm Land Rental Prices in Selected Landkreise (Administrative Districts) in Germany, 2005/06						
Region	Western Germany			Eastern Germany		
Landkreis <sup>1</sup>	HI	WF	BÖ	OK	EE	OSL
Acreage planted to sugar beets (percent)	22	19	7	3	.3	.0
Price of rental land (EUR per ha)	436	421	399	180	118	108

Source: Own calculations based on BMELV (2007).

<sup>1</sup> HI is Hildesheim; WF is Wolfenbüttel; BÖ is Bördekreis; OK is Ohrekreis; EE is Elbe-Elster; and OSL is Oberspreewald-Lausitz.

Sugar beet acreage has been selected because the prices of sugar and sugar beets are supported at very high levels. In fact, the minimum price of sugar typically is about two to three times the world market price. In addition to minimum prices, there are individual domestic production quotas which regionally are distributed rather unevenly. The Landkreise HI, WF, BÖ, and OK are in close proximity to each other and are characterized by very similar agro-climatic and soil conditions. However, they differ with regard to the relative importance of sugar beets. The differences in land rental prices, therefore, reflect the effect of sugar beet subsidies. The Landkreise EE and OSL have practically no sugar beet production and are characterized by poor soils. The low rental land prices, therefore, reflect both the absence of sugar beet subsidies and poor soils.

#### 4.2 Evidence for the United States

A regression was conducted using state level data for the time period 1998–2004, which included all states except Alaska, Hawaii, and several small states in the Northeast. This regression examined

the impact of cash receipts and government payments on agricultural land values. It also used a dummy for the five tobacco producing states to determine if a difference exists between tobacco and non-tobacco-producing states. The results of this regression are shown in Table 9.

All coefficients of this log-log model are statistically significant. The results show the relationship between cash receipts and land values to be positive. The coefficient of 0.5492 indicates that a one percent increase in cash receipts, be it through a market price increase, yield increase or through a subsidy, acts to increase land values by 0.5492 per cent. As in the case of rental prices in Germany, most of the benefits of subsidies go to the landowners. The percentage of subsidies ending up in the pockets of landowners is somewhat smaller than in Germany. This is not at all surprising. The reason is that there is an increasing demand for agricultural land for alternative uses. As increasing urbanization creates many opportunities for landowners, especially those on the urban fringes, to sell their farm land for development, many may no longer view profits

**Table 9: The Determinants of Agricultural Land Values in the United States**

Land value (log)	Coefficient	Standard Error	t	P > t
Constant	4.9153	0.1778	27.6400	0.000
Cash receipts (log)	0.5492	0.0353	15.5500	0.000
Govt. payments (log)	-0.2526	0.0550	-4.5900	0.000
Tobacco prod.	0.1513	0.0497	3.0400	0.003
yr1998	0.2053	0.0919	2.2300	0.026
yr1999	0.4358	0.1066	4.0900	0.000
yr2000	0.5152	0.1130	4.5600	0.000
yr2001	0.5456	0.1081	5.0500	0.000
yr2002	0.4620	0.0969	4.7700	0.000
yr2003	0.5243	0.1032	5.0800	0.000
yr2004	0.4739	0.1000	4.7400	0.000
R-squared = 0.5839				

Source: Own computations based on USDA/NASS (var. vols.), Gardner (2002) and Goodwin et al. (2003).

from agricultural production as the primary objective. Short-term farm profits may be viewed as a secondary objective that pales in comparison with the longer-term windfall profits which can be realized through development strategies. This view is supported by the positive time trend coefficients.

The effect of cash receipts on land values is corroborated by the coefficient for tobacco production. Tobacco production is characterized by large subsidies. It is, therefore, not surprising that the land values in the tobacco producing states is 15 percent above those of non-tobacco-producing states. This is in line with the results for sugar beet production in Germany. Sugar in the European Union is heavily subsidized. Hence the rental price of agricultural land increases with increasing sugar beet production.

For selected U.S. states, the incidence of subsidies has been detailed in Table 10 for a 10 percent increase in producer prices by means of a subsidy. As is evident, the bulk of the subsidy is capitalized into land values.

The impact of overall government payments was shown to be negative. However, this coefficient is difficult to interpret, as it reflects the effects of coupled and decoupled payments from two farm bills with quite different types of payments.

**Table 10: The Effect of a Subsidy Which Increases Cash Receipts by 10 Percent on Agricultural Land Values in Selected U.S. States**

<b>Tobacco Producers</b>	<b>Land Value (USD per acre)</b>	<b>Cash Receipts (USD per acre)</b>	<b>10% Cash Receipt Increase</b>	<b>Land Value Change (USD per acre)</b>
Kentucky	1162.86	148.68	14.87	63.86
North Carolina	2547.14	331.00	33.10	139.89
South Carolina	1480.00	241.23	24.12	81.28
Tennessee	2204.29	148.18	14.82	121.06
Virginia	2430.00	183.54	18.35	133.46
<b>Non-Tobacco Producers</b>	<b>Land Value (USD per acre)</b>	<b>Cash Receipts (USD per acre)</b>	<b>10% Cash Receipt Increase</b>	<b>Land Value Change (USD per acre)</b>
California	5661.43	2387.98	238.80	310.93
Florida	3560.00	3676.40	367.64	195.52
Illinois	2422.86	127.73	12.77	133.06
Iowa	2027.14	116.82	11.68	111.33
Minnesota	1380.00	100.85	10.09	75.79

Source: Own calculations based on NASS (var. vols.), BEA (2007) and Table 9.

# 5 CONCLUSIONS

**A**gricultural subsidies in the European Union and United States have been criticized for a variety of reasons:

- They lead to a misallocation of resources and reduce social welfare in those countries and in the world at large.
- They result in burdensome budgetary expenditures.
- They delay structural adjustment in agriculture which would make farms competitive.
- They are inequitable in that they benefit larger farms more than smaller farms.
- They erode incentives in developing countries to invest in agriculture, including human capital investment, thus aggravating malnutrition and poverty in these countries.

In this paper we have analyzed the impact of agricultural subsidies in the European Union on the German market for agricultural rental land and of U.S. farm subsidies on agricultural land values in the United States. We found that a large portion of agricultural subsidies ends up with landowners or sellers of land and not with the farm operators.

Of every Euro paid to German farmers, two-thirds is passed on to the landowners. This result is the consequence of rather conservative assumptions about the supply and demand elasticities, and should be considered a lower bound of the portion of agricultural subsidies that goes to landowners.

The operator is the intended beneficiary of agricultural subsidies in the European Union; however, as we have found, the main beneficiary is the landowner. Therefore, agricultural subsidies must be considered instruments that are poorly targeted to the intended beneficiaries. In fact, the shocking reality is that land rents in the absence of EU farm subsidies would be negative in most of Germany.

The effect of subsidies on land rental prices was further illustrated by analyzing the effect of sugar beet production on rental land prices. The price of sugar and of sugar beets is highly protected. It is not surprising then that we found such a strong positive relationship between sugar beet acreage and the price of agricultural rental land.

The results of our analysis of the impact of U.S. agricultural policy on farm land values are similar to those obtained for the EU rental land market. A one percent increase in subsidies acts to drive up land values by almost six-tenths of one percent. In the United States, tobacco has been a major recipient of subsidies. Not surprisingly, the land values in tobacco-producing states are 15 percent higher than in non-tobacco-producing states. In addition, over the past few years there has been a growing demand for agricultural land for development. This has acted to increase agricultural land values and has somewhat eclipsed the land value effect of subsidies. Therefore, the results for the United States presented here should also be considered the lower bounds for the impact of agricultural subsidies on land values.

# 6 REFERENCES

- M. C. Ahearn et al. "How do Decoupled Payments Affect Resource Allocations within the Farm Sector?" *Amber Waves* 2(3) (2007): 1-2.
- E. Bahrs and J.-H. Held. *Steigende Nachfrage auf den Energie- und Agrarrohstoffmärkten—Konsequenzen für die niedersächsische Landwirtschaft, die Bodenmärkte und die Agrarpolitik*. Department of Agricultural Economics and Rural Development, Goettingen University. Goettingen, 2007.
- BEA (Bureau of Economic Analysis), Regional Economic Accounts. United States Department of Commerce, Washington, DC. Data on the Internet: <http://www.bea.gov/regional/reis/default.cfm?&catable=CA45> , accessed June 2007.
- BMELV (Bundesministerium für Ernährung, Landwirtschaft und Verbraucherschutz), Specific Information Requested from the German Farm Accountancy Data Network (FADN). BMELV, Bonn, 2007.
- BMELV (Bundesministerium für Ernährung, Landwirtschaft und Verbraucherschutz), Agrarpolitischer Bericht der Bundesregierung. Bundesregierung, Berlin, var. vols.
- R. G. Chambers. "The Incidence of Agricultural Policies." *Journal of Public Economics* 57 (1995): 317-335.
- DESTATIS, (Statistisches Bundesamt). Fachserie 3, Reihe 2.1.6. DESTATIS, Wiesbaden, var. vols.
- H. Doll. *Zur Entwicklung auf den landwirtschaftlichen Bodenmärkten in den neuen und alten Ländern*. Bundesforschungsanstalt für Landwirtschaft, Braunschweig, 2002.
- European Union. Council Recommendation 2003/555 of 26 June 2003. European Union, Brussels, 2003.
- C. Fuchs. "The Influence of Per-hectare Premiums on Prices for Rented Agricultural Land and Agricultural Land Prices." *German Journal of Agricultural Economics* 51 (2002): 396-404.
- B. Gardner. *U.S. Commodity Policies and Land Prices*. Department of Agricultural and Resource Economics Working Paper, WP 02-02. The University of Maryland, College Park, Maryland, 2002.
- H. Gömann. *Auswirkungen einer Entkopplung von Ausgleichszahlungen auf den EU-Getreidemarkt*. *German Journal of Agricultural Economics* 51 (2002): 389-395.
- B. K. Goodwin et al. "What's Wrong with Our Models of Agricultural Land Values?" *American Journal of Agricultural Economics* 85(2003): 744-752.
- T. C. Hennessy and F. S. Thorne. "How Decoupled are Decoupled Payments?" *The Evidence from Ireland*. *EuroChoices* 4 (2005): 30-35.
- H. A. Höper. *Die Bestimmungsfaktoren des Bodenpreises, die Bodenpreisbildung und die Auswirkungen staatlicher Eingriffe gemäß Grundstücksverkehrsgesetz auf den Bodenmarkt*. Vauk, Kiel, 1985.
- F. Isermeyer. *Wirkung des Entkopplungsvorschlags der Europäischen Kommission*. Arbeitsbericht der FAL 1/2003, Bundesforschungsanstalt für Landwirtschaft, Braunschweig, 2003.
- C. Lippert. *Zu den Auswirkungen von Preisstützungen, flächengebundenen Prämien und personengebundenen Prämien auf Pachtpreise*. Technische Universität München, München, 2001.

Minnesota Land Economics, Land Value Data. Department of Applied Economics, University of Minnesota, St. Paul. Data on the Internet: <http://landeconomics.umn.edu/>, accessed June 2007.

Neue Landwirtschaft, Bodenmarkt 2006/2007. Special Issue, 2007.

OECD (Organization for Economic Cooperation and Development). European Union, Total Support Estimate. OECD, Paris, 2007.

C. Trivelli. "Agricultural Land Prices." Data on the Internet: [www.fao.org/sd/LTdirect/LTan0016.htm](http://www.fao.org/sd/LTdirect/LTan0016.htm), accessed May 2007.

R. Tyers and K. Anderson. "Disarray in World Food Markets." Cambridge University Press, Cambridge, 1992.

USDA/ERS (United States Department of Agriculture, Economic Research Service), Costs and Return Estimates, 2004/05, Wheat. Data on the Internet: [www.ers.usda.gov/Data/CostsAndReturns/testpick.htm](http://www.ers.usda.gov/Data/CostsAndReturns/testpick.htm), accessed 07 July 2007.

USDA/ERS (United States Department of Agriculture, Economic Research Service), Major Land Uses, Data Sets. USDA, Washington, DC. Data on the Internet: <http://www.ers.usda.gov/data/majorlanduses/>, accessed June 2007.

USDA/NASS (United States Department of Agriculture, National Agricultural Statistics), Service, Land Values and Cash Rents Summary. USDA, Washington, DC., var. vols.

H. von Witzke and S. Noleppa. "Distributive Effects of Direct Payments in German Agriculture under the New Common Agricultural Policy of the European Union." A Report to the German Marshall Fund of the United States. Berlin, 2006.

H. von Witzke and U. Hausner. "The Political Economic Myth and Reality of Agricultural Producer Price Support: The 'Agricultural Treadmill' Revisited." Issues in Agricultural Competitiveness. R. Rose et al. (eds.), Dartmouth, Aldershot 1997.

J. Zeddies. Vorschläge der EU-Agrarpolitik und Anpassungsmaßnahmen des Landwirts. Landinfo 9/2003: 2-5.



G | M | F OFFICES

WASHINGTON • BERLIN • BRATISLAVA • PARIS  
BRUSSELS • BELGRADE • ANKARA • BUCHAREST

[www.gmfus.org](http://www.gmfus.org)